

## Iridium GPS Dual Mode Whip Antenna Kit Contents

1. Antenna
2. Mounting bracket
3. Mounting Nut
4. SMA to TNC adapter
5. Lock washer
6. 4 x Mounting bolts
7. 4 x Split washers
8. 4 x Mounting nuts

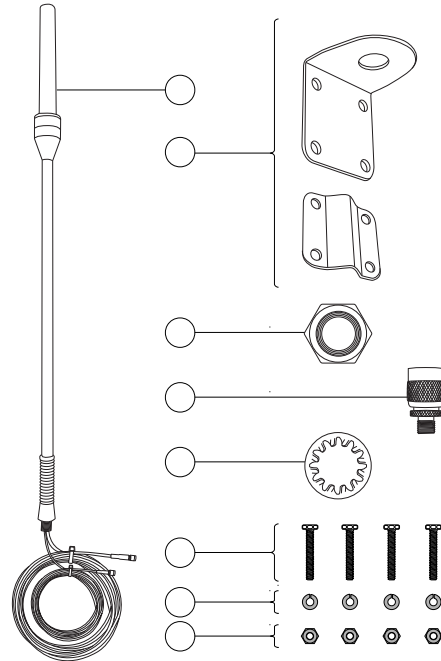

### Introduction

The Beam Iridium Dual Mode Whip Antenna (RST706) is intended for Land based applications. Designed to work with Beam Iridium products and other Iridium based devices.

Iridium Dual Mode Whip Antennas (RST706) excel in SUV/4WD/RV and Truck applications where a rugged antenna giving the highest possible clearance above the roof line is required. The antenna can be easily fitted to the bull bar of a vehicle and has 5 meters (16 ft) of cable included.

### Important Safety Information



#### **WARNING**

*Changes or modifications not expressly approved by Beam Communications could void the users authority to operate the equipment or the warranty.*

This device complies with Part 15 of the FCC Rules. Operation is subject to the following two conditions:

- (1) this device may not cause harmful interference and
- (2) this device must accept any interference received, including interference that may cause undesired operation.

#### **Antenna Installation Location**

The antenna should be attached in a location that provides the clearest line of site to the sky without obstruction or interference. Ideally the antenna should be fitted on the bull bar of a vehicle. Most bull bars already have a fitting and hole for this type of antenna, if not, then a suitable hole or fixing plate will be required.

### BEAM Communications Pty Ltd

8 Anzed Court, Mulgrave  
Victoria, 3170, AUSTRALIA

Tel: +61 3 8588 4500

Fax: +61 3 9560 9055

Info: [info@beamcommunications.com](mailto:info@beamcommunications.com)

Support: [support@beamcommunications.com](mailto:support@beamcommunications.com)

[www.beamcommunications.com](http://www.beamcommunications.com)



## Dual Mode Whip Antenna RST706

### Installation Manual



BEAM Communications Pty Ltd

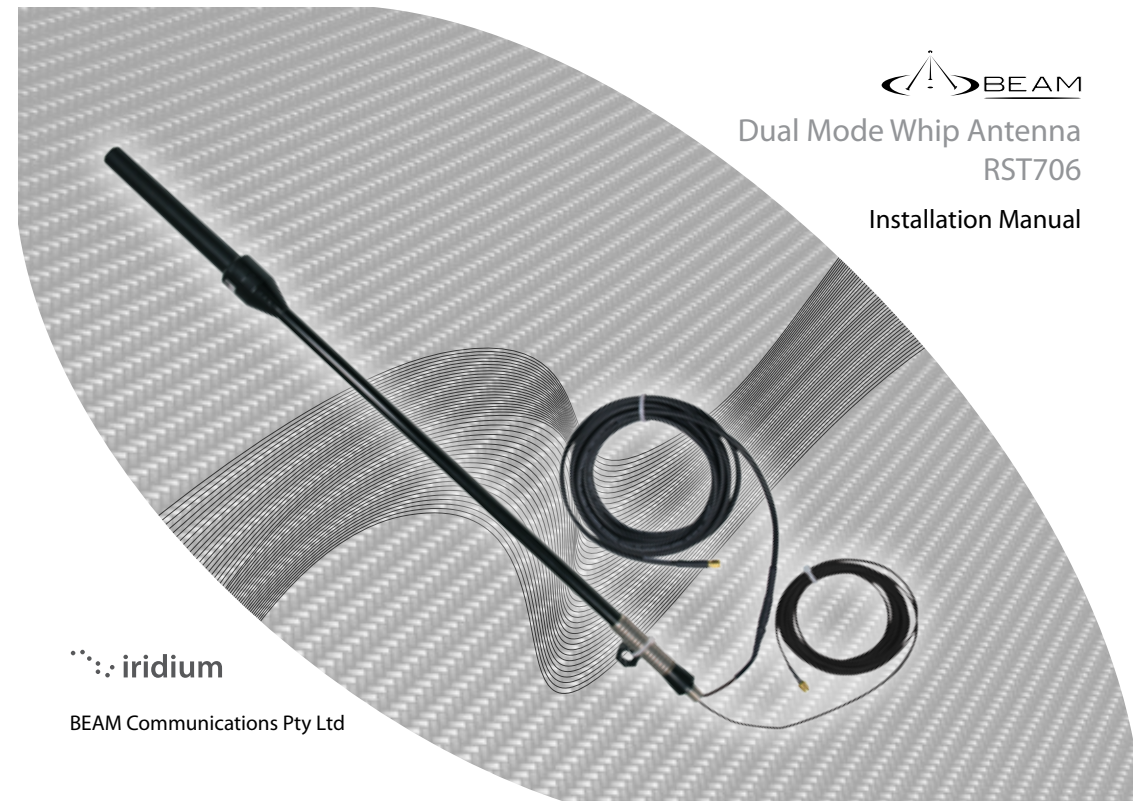

## Outside/Vehicle Installation Options

1. Fitting the antenna to an attachment point with a 16mm hole.

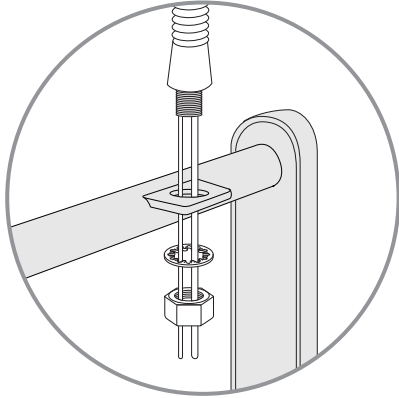

2. Use the mounting bracket to clamp to horizontal or vertical tubing.

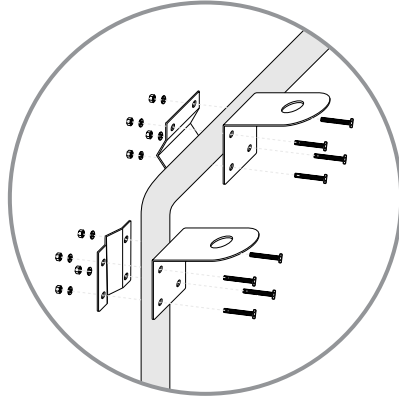

3. Attachment to a fixed support. Screw or bolt the angled plate to a support/structure.

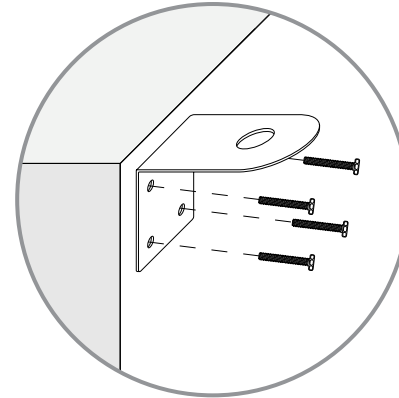

## Electrical Connection

Connect the SAT cable running from the antenna to the SMA/TNC adapter. Then connect the TNC adapter to the TNC connector on the loom coming from the dock or the TNC Bulkhead at the rear of the terminal.

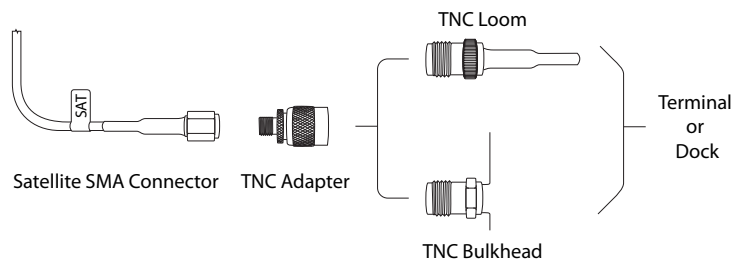

Connect the GPS cable running from the antenna to the SMA connector on the loom coming from the dock or the SMA Bulkhead at the rear of the terminal.

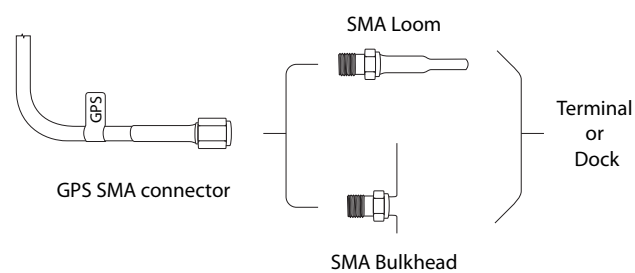

## Specifications

### General Specifications

Finish	Weatherable Polymer Black
Weight	0.822kg (1.812lbs)
Length	78cm (30.73 inches)
Width	3.8cm (1.50 inches)
Operating Temp	-40°C to +85°C (-40°F to 185°F)
Altitude	6,096m (20,000')

### Iridium Specifications

Frequency	1616 – 1626.5 MHz
Polarisation	Right Hand Circular
Axial Ratio	3dB max at bore sight
Impedance	50 ohms
VSWR	≤ 2.0:1
Power Handling	10 watts
Connector	TNC Male

Cable Includes 5m (16.4') of LMR240 Ultra Flex

### GPS Specifications

Frequency	1575.42 +/- 10MHz
Polarization	Right Hand Circular
Axial Ratio	3db Max at bore sight
Amplifier	Gain: 26 ± 2dB Noise Figure: 2.5dB max Impedance: 50 ohms VSWR: < 2.0 : 1 Voltage: 3.3V DC (35mA) Power Handling: 1 watt

Connector: SMA Male

Cable Includes 5m (16.4') of RG316