



Satellite and Radio
Communications System

RST820 SatRADIO

User and Installation Manual

Beam Communications Pty. Ltd.

SatRADIO RST820

User and Installation Manual

Version 5

Beam Communications Pty Ltd

**8 Anzed Court, Mulgrave,
Victoria, 3170, AUSTRALIA**

Information furnished by Beam Communications Pty Ltd (Beam) is believed to be accurate and reliable. However, no responsibility is assumed by Beam for its use, or for any infringement of patents or other rights of third parties, which may result from its use. No license is granted by implication or otherwise under any patent or patent rights of Beam. Beam reserves the right to change specifications at any time without notice.

Copyright © 2007-2009 Beam Communications Pty Ltd. All rights reserved

Product name: RST820 User Manual

Manual revision: 05

Part Number: USRMAN002905

Release date: August 2009

Package Contents

The RST820 package contents

- 1 x RST820 unit – including Iridium transceiver (internal)
- 1 x DC power cable
- 1 x Hex-Wrench for SIM cover
- 1 x Printed user manual
- 1 x Mounting Bracket Set (2 parts)
- 1 x Printed Iridium Antenna Guide
- 1 x RST970 Intelligent Handset

Optional Accessories

- *RST910 Iridium Helix Antenna*
- *RST920 Iridium Bolt-mount Patch Antenna*
- *UHF / VHF Antenna / cables*
- *Various Antenna cable lengths*
- *Iridium Antenna Tripod*

See your Service Provider for pricing and availability of these optional accessories.

User information

Please record your serial number here for future reference:



Model: BEAM RST820

Serial no.:



<input type="text"/>	<input type="text"/>	<input type="text"/>	<input type="text"/>	<input type="text"/>	<input type="text"/>	<input type="text"/>	<input type="text"/>	<input type="text"/>
----------------------	----------------------	----------------------	----------------------	----------------------	----------------------	----------------------	----------------------	----------------------

This number can be copied from the white shipping label on the RST820 box
eg. 100A2800

The following PIN codes may be required to use your RST820, please complete these details for future reference.

PIN Name	Function	Symptom	Your PIN						
SIM PIN <i>Supplied by your Service Provider</i>	Unlocks SIM card to enable calls to be made	Signal LED flashes Red	<table border="1"> <tr> <td><input type="text"/></td> <td><input type="text"/></td> <td><input type="text"/></td> <td><input type="text"/></td> </tr> </table>	<input type="text"/>	<input type="text"/>	<input type="text"/>	<input type="text"/>		
<input type="text"/>	<input type="text"/>	<input type="text"/>	<input type="text"/>						
PUK <i>Supplied by your Service Provider</i>	Unlocks a locked SIM card	Signal LED flashes Red	<table border="1"> <tr> <td><input type="text"/></td> <td><input type="text"/></td> <td><input type="text"/></td> <td><input type="text"/></td> <td><input type="text"/></td> <td><input type="text"/></td> </tr> </table>	<input type="text"/>	<input type="text"/>	<input type="text"/>	<input type="text"/>	<input type="text"/>	<input type="text"/>
<input type="text"/>	<input type="text"/>	<input type="text"/>	<input type="text"/>	<input type="text"/>	<input type="text"/>				
User PIN <i>Supplied here</i>	Allows access to user menu of RST820 via log port	Enter PIN on console	<p style="text-align: center;">9 8 7 6</p> <p style="text-align: center;">Default setting</p>						
Supervisor PIN <i>Supplied here</i>	Allows access to supervisor menu of RST820 via log port	Enter PIN on console	<p style="text-align: center;">3 1 7 0</p> <p style="text-align: center;">Default setting</p>						



SIM PIN Note: The SIM PIN prompt on power-up can be disabled, so it does not need to be entered each time. This is changed in the DPL Handset menu, under "Security Settings/Require SIM PIN".

Contents

PACKAGE CONTENTS	3	MAKING A CALL.....	15
THE RST820 PACKAGE CONTENTS	3	ACCESSING QUICK (SPEED) DIALS FROM RADIO	
OPTIONAL ACCESSORIES.....	3	HANDSET	16
SIM PIN	4	ANSWERING A CALL	16
PUK.....	4	<i>Answering on a Radio</i>	16
User PIN.....	4	<i>Auto Answer</i>	16
Supervisor PIN	4	INTELLIGENT HANDSET MODE (IF FITTED).....	17
SAFETY INFORMATION	6	TRANSFERRING INTELLIGENT HANDSET MODE	
<i>Conventions in this Manual</i>	6	TO RADIO MODE	17
<i>Exposure to Radio Frequency Signals</i>	7	<i>Autodial Mode - Quick Dial</i>	18
ABOUT BEAM COMMUNICATIONS	8	<i>Setting up Autodial Mode</i>	18
ABOUT YOUR RST820 SATRADIO	9	VOX OPERATION – UNDERSTANDING THE	
USING RST820 SATRADIO	10	OPERATION	18
GETTING STARTED	11	LED STATUS.....	19
<i>Tools required</i>	11	<i>Call (Orange)</i>	19
RST820 CONNECTOR OVERVIEW	12	<i>Signal</i>	19
<i>Connecting the Antenna Cable</i>	12	INTELLIGENT HANDSET RST970	20
<i>Connecting the Power Cable</i>	12	INSTALLING THE ANTENNA - REFER TO	
<i>Connecting the Radio Interface Cable</i> ...	12	SEPARATE GUIDE	20
<i>Connecting to the Comm Port (if required)</i>	12	DATA COMMUNICATIONS	21
.....	12	RS232 SPECIFICATION	21
<i>Connecting to the Log Port (if required)</i> .	12	PHYSICAL CONNECTION	21
RST820 OPERATION	14	INTERNAL RS232 PORT SIGNAL SUPPORT AND	
SYSTEM POWER UP	14	HANDSHAKING.....	22
OPERATING THE TWO-WAY RADIO.....	14	RS232 PORT ELECTRICAL PARAMETERS.....	22
OPERATING THE SATELLITE MODULE.....	14	RADIO INTERFACE	23
<i>Autodial Mode</i>	14	TROUBLESHOOTING	25
USING A RADIO HANDSET – DTMF MODEL....	15	CONFIGURATION – TECHNICAL NOTES .	27
		SPECIFICATION SUMMARY	29
		BEAM WARRANTY CONDITIONS.....	31

Safety Information



IMPORTANT! Please read the following information carefully before installing and using this BEAM equipment. Failing to follow instructions may compromise the safety of the product and may result in personal injury and/or equipment damage. Please consult your supplier if you have any further questions.

Your RST820 is a low power radio transmitter and receiver, when ON, it receives and sends out radio frequency (RF) signals.

The design of your RST820 system complies with international safety standards.

Refer to the appropriate section of this *RST820 Installation & User Manual* for additional safety information.



Warning:

Do not open equipment. There are no user-serviceable parts inside. If a DC power supply is to be used, its output must comply with the Safety Extra Low Voltage (SELV) requirements of IEC60950.

All connectors must only be connected to equipment ports which comply with the Safety Extra Low Voltage (SELV) requirements of IEC60950.

Conventions in this Manual

Warnings, cautions and notes appear throughout this manual and are represented by following conventions:



Warning: This symbol and associated text indicate a warning note providing information to prevent personal injury or damage to equipment.



Note: This symbol and associated text indicate a note providing general operating information.



Interference: All wireless phones may get interference, which could affect performance.



Record: Write details of your unit for easy reference when required. Ideal for troubleshooting.

Exposure to Radio Frequency Signals

Your wireless mobile telephone is a low power radio transmitter and receiver. When it is ON, it receives and also sends out radio frequency (RF) signals.

International agencies have set standards and recommendations for the protection of public exposure to RF electromagnetic energy.

- International Commission on Non-Ionising Radiation Protection (ICNIRP) 1996
- Verband Deutscher Elektrotechniker (VDE) DIN-0848
- United States Federal Commission, Radio Frequency Exposure Guidelines (1996)
- National Radiological Protection Board of the United Kingdom, GS 11, 1988
- American National Standards Institute (ANSI) IEEE. C95. 1-1992

These standards are based on extensive scientific review. For example, over 120 scientists, engineers, and physicians from universities, government health agencies, and industry reviewed the available body of research to develop the updated ANSI standard.

Your RST820 utilises the Iridium L-Band satellite Transceiver, which is a low power radio transmitter and receiver. When it is ON, it receives and sends out radio frequency (RF) signals.

The SatRADIO Portable system contains a Li-Ion battery unit with high energy density. Do not disassemble, puncture, throw, drop, crush, bend, or modify this battery unit. Do not charge the battery while on an airplane.

Store the system in a cool and dry area.

It is important to monitor the heat inside the unit in the event that the case lid is closed during operation.

Do not obstruct the main panel vent holes, or to the rear of the panel, as this may cause overheating.

Do not submerge the system in water.

Do not place foreign metal objects or debris in the system. If debris falls into the system, please return to factory for service.

About BEAM Communications



BEAM Communications, is an authorised manufacturer of Iridium Satellite products.

BEAM develops subscriber products that utilise the Iridium satellite network of Low Earth Orbit satellites, known as LEOs. The Iridium network is extensively used around the world by commercial enterprises and defence agencies.

BEAM products address the needs of individuals, communities, government agencies and the corporate sector, providing voice and data access without the need for traditional wire-line or mobile phone infrastructure.

As the Iridium satellite network is global, BEAM products address global markets, across the spectrum of rural and remote users, including households, motor vehicles, telemetry, maritime and emergency services.

BEAM Communications Pty Ltd
8 Anzed Court, Mulgrave,
Victoria, 3170, AUSTRALIA

Web: www.beamcommunications.com
Info: info@beamcommunications.com
Support: support@beamcommunications.com
Tel: +61 3 8588 4500
Fax: +61 3 9560 9055

About your RST820 SatRADIO

The **RST820** is a Portable Radio over Satellite system for connecting a radio network to a base station or phone call party over the Iridium network.

The **RST820** extends your existing Radio network using an Iridium satellite link with an easy-to-deploy portable solution in a self-contained rugged carry case.

The **RST820 SatRADIO** works by becoming another participant in your local radio net, with the other end of the satellite connection anywhere in the world: your central base, or another remote radio net.

The **SatRADIO** provides useful features such as field radio-handheld dialling (via DTMF tones) and sends acknowledgement tones back over the radio to indicate current state. It can be set up to operate in a number of ways best suited to your situation, such as auto-dial which automatically re-establishes the Satellite link if the phone call drops out. The system can also provide the ability to auto answer any incoming call.

The **SatRADIO** can be incorporated into any suitable two-way radio system. This radio equipment is supplied separately and configured separately for VHF or UHF.

The system is powered from a 10 to 32V DC source. It also provides a data connection and Satellite SMS access.

The complete **RST820** provides total peace of mind, flexibility and a rapid deployment solution for government, military, and emergency service applications.

Using RST820 SatRADIO

The **RST820** is software configurable to operate in a number of ways to best suit your situation. This mostly relates to how the satellite call is initiated.

- Auto-answer. Regardless of any locally initiated call out operation, the **SatRADIO** can be setup to auto-answer an incoming call. Once answered the remote caller participates in the local radio net.
- Manual-answer. An incoming satellite call causes an intermittent ring tone to be transmitted out to the local radio group. Any member of the local group can answer the call by sending a DTMF-0.
- Auto-dial last number (Re-Dial mode). When the **SatRADIO** and the radio are both on, the unit will immediately try to call the last number that was dialed on the Iridium handset. This mode is most useful for emergency services where a quick and easy method of connecting the local net to central command is required. If the call ever drops out, the **SatRADIO** will attempt to redial the number again.
- Auto-dial fixed number. In cases where only one remote number is ever to be called, instead of calling the last dialed number, the unit can always dial a user-preset number.
- Manual-dial. Any member of the local group can request a satellite call using DTMF dialling on the radio handset. A user PIN entry (default 9876) is required prior to the phone number entry to add security. A manual call can be hung-up either at the remote end, or by sending DTMF-0. NOTE: Calls initiated from the Intelligent Handset cannot be terminated from the Handheld radio.
- Manual-quick-dial. Similar to manual dial, except that a quick dial number is called instead of the full phone number. 10 quick dial numbers are available and are called by using the sequence PIN 0->9,*, to select the number.
- Handset Call. The Iridium handset (optional) can be used to make a satellite call. Audio is routed to the handset rather than the radio channel.

The **SatRADIO** always give priority to the local group communications. If a local user is transmitting at the time, even if the remote person speaks, the **SatRADIO** will not key up the transmitter till the local person stops transmitting.

Getting Started

The **RST820** requires that a valid **Iridium** or **Telstra Mobile Satellite** SIM card to be installed. This is not included in the **RST820** kit and you should consult your place of purchase if you do not have an active SIM card enabled to make Iridium Satellite calls.



Warning: To prevent possible damage, make sure the **RST820** system is completely switched **OFF** before installation.

Tools required

- Philips-head screwdriver
- Allen Key (supplied)



Note: Be careful to ensure that when you are removing or installing the antenna or adaptor that the handset power is turned **OFF**. The handset should not be turned on until after the connector cable is attached also.

Step 1: Ensure the System is switched off.

Step 2: Open the case lid.

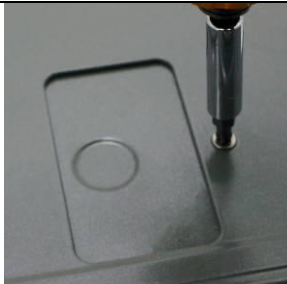
			
<p>Step 3: Using a Philips screw driver, remove the black steel cover plate.</p>	<p>Step 4: Remove next screw, and slide back the cover.</p>	<p>Step 5: Use the Allen Key, and remove the 2 socket-head screws, and insert the SIM card.</p> <p>(HINT: <i>carefully</i> using the hex-wrench can help slide the plastic SIM holder)</p>	<p>Step 6: Replace and re-fit all screws and covers.</p>

RST820 Connector Overview



Connecting the Antenna Cable

Plug the antenna cable into the TNC antenna jack located on the rear panel of the RST820 case. Ensure that the specified cable being used does not exceed the Iridium maximum-loss rating of 3dB to ensure maximum performance of the terminal. Refer to your Service Provider for full details or to purchase an approved cable if using a cable other than the magnetic mount antenna included.

Connecting the Power Cable

Plug in power cable into the 2-pin power socket located on rear panel of the RST820 case. Attach the free ends to the correct terminals of the DC power supply, being careful to observe polarity.

Connecting the Radio Interface Cable

Connect the cable to the HD-15 connector labelled Remote Status Indicator. Refer to the Radio Interface connection table for pin designations and signal requirements.

Connecting to the Comm Port *(if required)*

Connect a PC/Laptop to the **Comm Port** to make dial-up modem calls. The Iridium data speed is 2400bps, and can be as high as 10kbytes if using Direct Internet compression. A data call cannot be made at the same time as a voice call.

Connecting to the Log Port *(if required)*

Connect a PC/Laptop to the Log port to use the Beam Management System. The **Log Port** should only be used for configuration and control of the terminal equipment.

Note: Both ports are wired DCE and require a straight through cable.

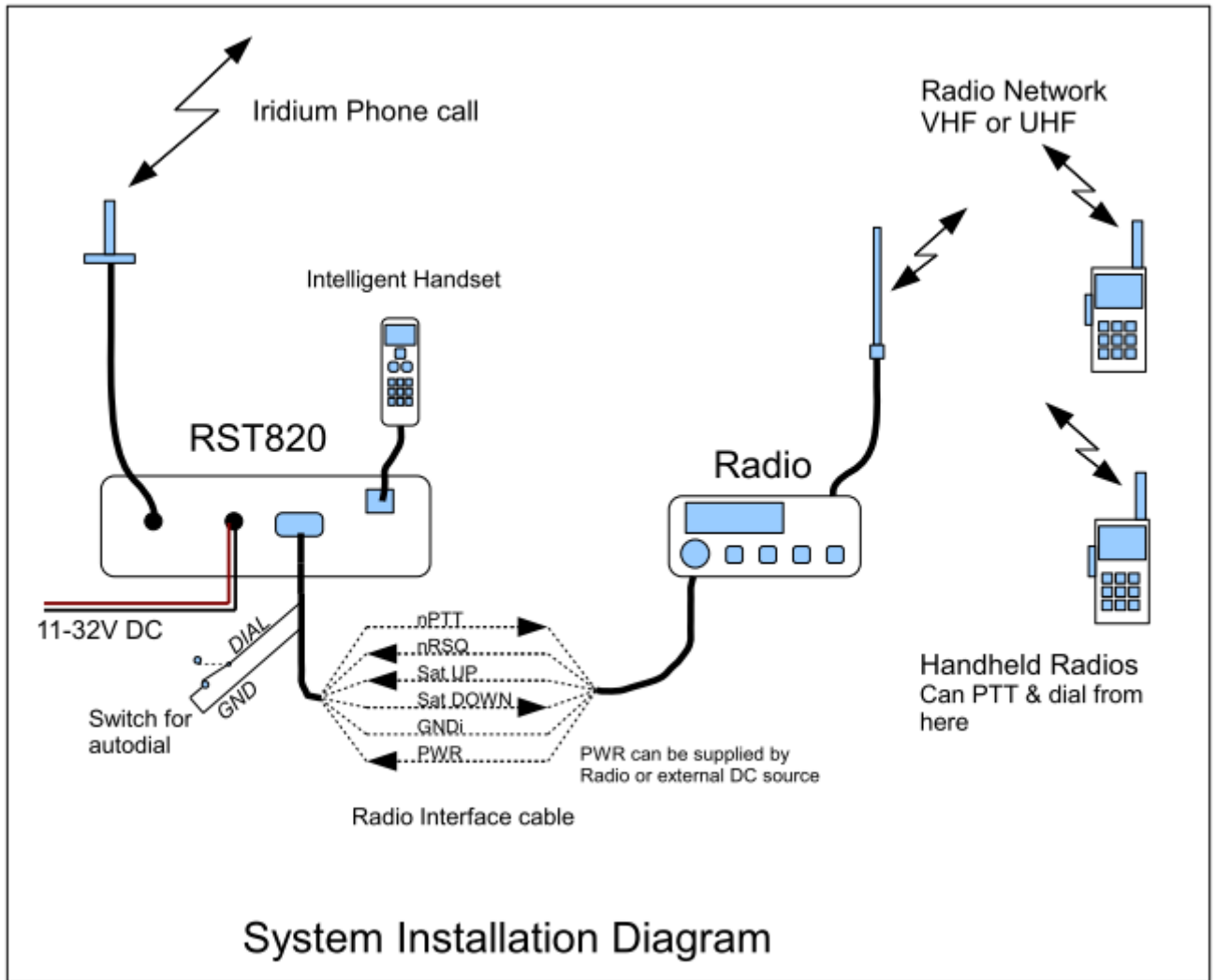

RST820 Operation

System Power up

After installation has been completed, the RST820 system is now ready to be switched on. To turn on the system:

1. Apply power to the attached radio and RST820.
2. Wait for the Signal LED to stay solid green or, the DPL Satellite Handset (if fitted) to show registered status. This will typically take 40 to 60 seconds.
3. A call can now be attempted.

Operating the Two-Way Radio

The RST820 is required to be installed with a Two-way radio that will be to the compatible specification. The Radio component needs to be tuned to your desired channels to ensure that it can communicate with other radios within your user group. Tone or CTSS squelching schemes should be programmed as required.

To ensure optimum performance check the following

1. Ensure the Radio component is switched on and initialised.
2. Ensure that the other Radios you want to interface with this unit are on the same frequency as the RST820 main terminal.
3. Test that from the Radio Control handset you can talk to the other radios on the same Frequency / Channel. If not, ensure that the correct Channel has been selected and any required CTSS or tone squelch has been set up correctly.
4. If you do not believe that you have communications between your Radio's consult your radio provider to ensure the unit has been programmed to your required channel set up.

Operating the Satellite Module

Autodial Mode

This mode enables the RST820 to continuously keep connected into a preset destination (phone number). This is ideal for emergency or disaster recovery situations when the terminal may be being used as a primary communication tool or a replacement for a Radio link that is down.

Using a Radio Handset – DTMF Model

Using a DTMF compatible Two-way Radio it is possible to make or receive a call over the satellite network on the Radio device. To make a call from a Radio handset a PIN is required. This is configurable to protect against unauthorised calling.

Making a call

1. Ensure that the Autodial switch on the RST820 terminal is turned **OFF** (pin 15 connected to GND) as it is not possible to override this autodial active mode. This function is enabled from the Dial input of the Remote Status Indicator port and is either an external switch or a hard-wired link to ground in the connector.
2. Ensure the radio handset is on the same frequency as the main radio unit.
3. Ensure the Satellite & Radio units are both powered **ON**
4. Whilst pressing the transmit button of the radio enter the PIN (default 9876) to access the system.
 - a. If PIN accepted a couple of acceptance pips are issued to indicate it is now ok to dial the phone number.
 - b. If the PIN number fails the handheld user receives a rising crescendo tone.
 - c. The access (after the PIN has been entered) times out after approx 10 seconds, after which the PIN would need to be re-entered.
 - d. In the event you have trouble entering the correct PIN wait 20 seconds in between tries to allow the unit to reset.
 - e. Remember that it is not possible to transmit DTMF tones whilst another party is transmitting on another radio in the group.
5. Once the acceptance pips are heard depress the transmit button and enter the full number you wish to call, and then release the button.
 - a. Usually the transmit button of the radio needs to be pressed the entire time the number is being entered in order to transmit the tones to the base unit.
 - b. If the dialled number seems to be a valid format acceptance pips will be transmitted to the handheld from the satellite base.
 - c. If the number is invalid then a FAIL tone is sent; a long, low, beep.
6. Progress calling tones will be heard whilst the call connects, if the number was incorrect or the satellite network is not available a busy tone will be heard through the radio network.
7. Hanging up the call: If the call was manually dialled or was incoming, it can be hung-up by the handheld user by simply pressing the transmit button of the radio followed with a DTMF- 0 (zero). NOTE: You cannot use the radio handset to hang-up a call that was initiated or answered on the Intelligent Handset.



NOTE: Transmission of any DTMF tones will only transmit whilst the transmit button of the two-way is depressed and there is no other activity on the Radio channel

Accessing Quick (Speed) Dials from Radio Handset

The quick-dial mechanism can also be used if any of the quick-dial numbers have been setup in the SatRADIO.

Dial PIN, then a digit between 0->9 then *, to identify the quick dial number.

The quick dials can be programmed only using the Beam Management System when connected with a PC to the Log port.

The quick dials are accessed in the following way:

1. Ensure the quick dial locations have been programmed in the main satellite terminal
2. Enter the PIN from the handset as per above instructions
3. Once acceptance pips received enter a Quick Dial location digit between 0->9 then *, obviously only those locations that have been preconfigured can be called in this manner.

*e.g. if you enter your PIN followed by 2 * this would dial the preset Quick Dial in location 2.*

Answering a call

There are two ways of answering a call on the two-way radio, by either using the DTMF controls on the handheld to accept the call or if you want all incoming calls answered automatically then this can be configured on the terminal.

If fitted, the Intelligent Handset can be used to answer a call by pressing the **OK** button.

Answering on a Radio

A RING signal will be intermittently transmitted on the Radio channel and the handheld user can reply to answer the incoming call by sending a DTMF-0 to answer the incoming call.

Note: The DTMF-0 must be sent in the gap between rings for it to be heard by SatRADIO.

Auto Answer

The firmware can be set to automatically auto-answer an incoming call as long as the Radio is ON. **This is the default setting.**

Note: Auto answer cannot work concurrently with Autodial being ON

Intelligent Handset Mode (if fitted)

This mode enables you to make a satellite telephone call using the Intelligent handset of the terminal. Take the handset off the cradle and make a satellite call as though you were using a typical cellular telephone.

To make a satellite call:

1. Remove the handset from the cradle by pushing the handset up
2. Enter the phone number you wish to call.
 - a. Consult your Satellite SIM provider for standard dialling instructions as this may vary depending on the type of satellite SIM used
3. Once the number has been entered press the **OK** button to commence calling
4. To terminate the call simply press **C**, or return the handset to its cup.
5. To adjust the volume in call simply press the arrow up/down on handset.

Transferring Intelligent Handset Mode to Radio Mode (for calls initiated or answered on the Intelligent Handset)

It is possible to make a call (or answer a call) on the Intelligent Satellite handset and then transfer the call through to the Radio network. **You MUST connect the Dial input signal to a toggle-switch or other form of relay connection to change between input voltages.**

1. Answer an incoming call on the Intelligent Handset keypad, or make a call on the Intelligent Handset.
2. During the call, activate the “Dial” input by placing it in the ENABLED (positive + voltage) position (for greater than 1sec). The call will now be routed to the radio audio circuit.
3. Toggle the switch for the “Dial” input by switching it back to the DISABLED (GND voltage) position. This does NOT hang up the call. Pressing DTMF-0 on the handheld radio returns the call to the Intelligent Handset
4. End the call by pressing **C** on the Intelligent Handset. **NOTE:** The call cannot be terminated from a radio if it was originated or answered on the Intelligent Handset.
5. Repeat steps above for transferring the next call when required.

NOTE 1: “AutoDial” (in Beam Management Settings) must be disabled.

NOTE 2: “Auto Answer” (in Beam Management Settings) must be disabled.

NOTE 3: If the “Dial” input remains in the ENABLED (+ve) position after the call is ended, this instructs the RST820 to operate in “auto-redial” mode. It will attempt to automatically call the last number that was originated from the RST820 system. This is a similar function

(but not the SAME) to the “AutoDial” mode which is instead enabled from the Beam Management System.

Autodial Mode - Quick Dial

This mode enables the RST820 to continuously maintain a phone call link to the number in Quick Dial position “0” (if configured). This is ideal for emergency or disaster recovery situations when the terminal may be being used as a primary communication tool or a replacement for a Radio link that is down.

As soon as the SatRADIO is powered on and registered, the RST820 will attempt to automatically call this number, and maintain this call by redialling automatically.

Setting up Autodial Mode

The Quick Dial Autodial feature uses the Quick Dial memory location “0” of the satellite terminal. This enables a fixed telephone number to be programmed for a permanent application where the SatRADIO is always required to call the same location.

These settings are PIN protected using the Beam Management System and can only be changed by an authorised person.

VOX operation – Understanding the operation

Once the voice call is in progress, the base operator can hear all traffic on the Radio channel (assuming the SatRADIO has been setup with Selcall or CTSS compatible with the local radio user group).

Whilst the radio is receiving a signal, the base operator cannot be heard (local priority). If the channel is clear, when the operator speaks the SatRADIO transmits on the channel. The threshold of this voice operated switch (VOX) can be adjusted, as well as the tail (how long it keeps transmitting after the remote speech stops).

The status indicators are located on the main panel of the RST820.

LED Status



Call (Orange)

Indicates the status of the call, **either** a data or voice call. The LED indicates:

- In Call (Flashing)
- Waiting to connect (constant)
- Incoming call (cadence flash)
- Data port active (constant)

Signal

The Signal Strength LED gives an indication of how strong the signal is from the Iridium network at your location. This LED displays different colours to indicate the strength of the RF (Radio Frequency) signal and different on/off conditions to indicate the terminal status.

Indicator colour	Signal strength
Flashing	RST820 is registering with the network – please wait
Green	Usable Signal
Red	No signal, check installation

The Signal Strength LED reading will vary in status in relation to the quality of the Signal being received by the terminal. There are many factors that will affect the signal strength including, local RF interference, poor antenna cabling or exceeding the 3DB loss limit, poor line of sight or other environmental conditions affecting signal penetration to the antenna system.

Intelligent Handset RST970

The RST820 is capable of supporting voice services on the Iridium network through the use of the DPL Intelligent handset. The Intelligent handset enables you to access Voice and SMS services over the Iridium network in conjunction with the RST820 terminal interface.

A Beam Communications approved extension cable to the Intelligent handset is optionally available.

The DPL Handset is inserted and removed from the cup by pushing forward against the spring-loaded arch.



A: The RST820 is only compatible with the second generation (DPL bus) type Iridium Intelligent handset. The Intelligent Handset should only be disconnected and or connected when the power is OFF.

B: Inserting the DPL handset back in the cup WILL terminate an active call, (unless the magnet internal to the cup is physically removed: doing so voids the warranty of the Intelligent handset cup).

Installing the Antenna - refer to separate guide

See the specific *“Iridium Antenna Guide”* or visit www.beamcommunications.com

Data Communications

A 9 pin serial communications port (Comm Port) is provided for data communications over the Iridium satellite channel. Data calls cannot be made when the terminal is busy in a voice call with the handset or radio.

The interface is wired DCE, so appears as a normal Hayes modem to a computer. Standard AT Hayes commands can be used to initiate a Data call using this port. Refer to RST100 AT command reference.

Asserting DTR on this port precludes use of the SatRADIO for voice services, unless the Activity timeout is also used. Refer to the RST100 Manual Data Connections for more information on sharing voice and data services.

RS232 Specification

The RST820 is provided with two RS232 serial ports for configuration (Log Port) and data (Comm Port) connection. Both are 9-pin D-type (female) sockets, wired DCE for connection to a standard PC with a 1:1 cable.

Physical Connection

The pin-out of both connectors is described in the following table:

Pin	Signal	Direction	Description
1	DCD	RST→PC	Data Carrier Detect
2	RXD	RST→PC	Received Data
3	TXD	PC→RST	Transmitted Data
4	DTR	PC→RST	Date Terminal Ready
5	GND		Signal Ground (Common)
6	DSR	RST→PC	Data Set Ready (CTS and DCD)
7	RTS	PC→RST	Request to Send
8	CTS	PC←RST	Clear to Send
9	RI	RST→PC	Ring Indicate (7.5V on Log port)

Internal RS232 Port Signal Support and Handshaking

On the Comm port, DCD and DSR output signals are related to DTR input and CTS is tied to RTS as shown. The Comm port supports full software XON/XOFF handshaking on data (AT commands bypass this as standard for Hayes modems) or full hardware handshaking on RTS/CTS with DCD carrier indication.

The Log port has no software handshaking support and hardware handshaking is loop-back only since the command set requires a minimal buffer.

RS232 Port	
Comm Port	Log Port
DCD	DCD = DTR
RXD	RXD
TXD	TXD
DTR	DTR
DSR	DSR = DTR
RTS	RTS
CTS	CTS = RTS
RI	RF=HIGH

RS232 Port Electrical Parameters

The Comm and Log Ports conform to the RS232 interface specification with the following parameters, however the Log Port communicates only at 9600:

Parameter	Specification
Communication Rate	220 to 115,200 Baud
Protocol	1 start bit, 8 data bits, no parity, 1 stop bit, asynchronous.
Voltage Levels and Sensitivity	RS232 compliant

Radio Interface

The Remote Status Indicator port provides audio and control/status for interfacing to an external radio. (Cables can be supplied when ordered extra).

Pin No.	Signal	Direction	Function
1	nPTT	Output	Key transmitter. Active low. Requires external 15K ohm pull-up. Max 16V
2	Sat UP	Input	Rx Audio (unbalanced) from radio for satellite uplink. Typ. 0.5V RMS
3	POWER LOST	Output	Indicates a loss of 7.5V supply regulation. Closed on Fail relay contact
4	nEXT	Input	Normally high (7.5V). Pull below 2V to activate
5	Call LED	Output	Indicated the condition of CALL LED. 7.5V on, <3V off. Not isolated
6	PWR	Input	Enables SatRADIO functionality. Connect to 11-32V to enable
7	GNDi		Isolated GND. This is the common for the relay contacts, Sat UP, Sat DOWN, PWR, nPTT and nRSQ
8	NOT REGISTERED	Output	Satellite has not maintained registration. Closed on Fail relay contact
9	Signal Led Red	Output	Indicated the condition of the RED Signal LED. 7.5V on, <3V off. Not isolated
10	GND		Is used as return GND connection to disable "Dial" signal. Note that all other minimum required signals are referred to GNDi
11	nRSQ	Input	Received audio squelch signal (gated RSSI). Active low when there is received audio from the radio. Requires an open collector driver capable of sinking > 2mA
12	Sat DOWN	Output	Satellite downlink audio (unbalanced) to radio transmitter. Typ. 0.5V RMS
13	HIGH TEMP	Output	Internal PCB temperature sensor has reached a pre-defined maximum. Closed on Fail relay contact
14	AUX	Input	Normally high (7.5V). Pull below 2V to activate
15	Dial	Input	Enables auto-dial of a pre-defined number, or used for call transferring from DPL handset to radio. Pull below 2V to disable [Referred to GND not GNDi]. Floats high.

The minimum required signals are:

- **GNDi**
- **Sat UP** from the radio receiver audio
- **Sat DOWN** to the radio transmitter audio

- **nPTT**
- **nRSQ.**
- The **PWR** input must be connected to a DC supply of 10-32V
- Connect the **DIAL** input via a switch to the **GND** (not GNDi) signal. Connecting directly to **GND** will disable autodial capability.

Troubleshooting

This chapter provides information to help you troubleshoot problems you may encounter while running the RST820.

Q **No lights on RST820**

A *Check that DC power cable is correctly attached and the external supply is adequately specified.*

Q **No dial tone**

A *Check if a data call is in progress and power is connected and equipment is in a normal state*

Q **Cannot make call, two tone signal heard**

A *Phone requires a PIN or PUK, refer to the handbook*

Q **You can't make calls.**

A *Check that the antenna is properly mounted.*

Do you have a clear view of the sky?

Did you enter the number in international format?

All calls made from the Iridium System require a special calling sequence; please refer to your Service Provider for these details.

Check the signal strength meter. If the signal is weak, move the antenna to a more open area.

Check the Network Selection settings.

Check your Operator coverage map.

Is Restricted displayed? Check the Call Barring setting.

Has a new SIM card been inserted?

Q **You can't receive calls**

A *Check to see that your phone is powered on.*

Check the antenna. Is it properly mounted?

Do you have a clear view of the sky?

Check the signal strength. If the signal is weak, move the vehicle to a more open area.

Check the Call Forwarding and Call Barring settings.

Q **You can't make international calls.**

A *Have you included the relevant codes? Press and hold the (+) key to display the international dialling prefix (+), and then enter the appropriate country code, followed by the phone number.*

Q **Your PIN is blocked**

A *Enter the PIN unblocking key (PUK1) or contact your service provider*

Q Your PIN2 is locked.

A Enter the PIN2 unblocking key (PUK2) or contact our service provider.

Q Your SIM card won't work.

A Is the card inserted the correct way?

Is the gold chip visibly damaged or scratched? Return the card to your service provider.

Check the SIM and phone contacts. If they are dirty, clean them with an antistatic cloth.

Q You can't cancel call forwarding or call barring

A Wait until you are in an area with good network coverage and try again.

Q Your terminal has the SIM card inserted but the display says: Enter PUK

A Enter the PIN unblocking key (PUK1) or contact your service provider

Q Your PIN is blocked

A Check Card or Insert Card.

Check the card is inserted correctly

Check the contacts of the card are clean

Clean the chip with a soft cloth

See your Service Provider if continues

Q Can make a call however no audio coming via the Radio

A Check the Radio is configured correctly

Check the CTSS/Channel Selcall

Configuration – Technical Notes

Configuration of the SatRADIO can be performed by a user with sufficient privileges, and is usually required on initial installation to program the way the unit is to operate and adjust levels.

Configuration is simple and can be done with any PC. An RS232 serial connection is required which can be either provided by the PC itself, or a USB->Serial converter. The serial port is connected to the CONFIG port on the SatRADIO with a direct 9 pin serial cable. A utility called “BMS” (Beam Management System) provided on the CD should be installed on the PC. You will need a supervisor PIN in order to be able to use the BMS.

There are many items that can be programmed with the BMS. Many relate to a normal RJ-11 phone installation rather than a SatRADIO and are not relevant, but here are some that are particularly relevant to a SatRADIO installation:

- **Supervisor PIN:** This 4 digit PIN number can be changed to protect access to the configuration. Make sure you remember the new PIN though, and be able to supply it if ever you need to contact Beam Support.
- **User PIN:** This 4 digit PIN is used to access to the call records, and is also the Manual-dial PIN required to be entered on a radio handset prior to the phone number when using DTMF calling.
- **Ring tones:** If you are using manual-answer, the 2nd ON and OFF times are very important. The ON time determines how long the ring tone is, the OFF determines how much time in between rings a user has to hit DTMF-0. Note that a DTMF-0 cannot be sent to the SatRADIO while the ring tone is being transmitted as the SatRADIO is half-duplex like any radio.
- **Dial Tone:** The configuration of this tone is used for the acceptance pips on SatRADIO.
- **Unavailable Tone:** The configuration of this tone is used for the Fail/No-Service tone on the SatRADIO.
- **Local Ring:** If set then manual-answer using DTMF-0 is configured. If clear then auto-answer incoming calls is configured.
- **DTMF timeouts:** Usually set longer for SatRADIO than a normal phone installation because it's harder to dial on a handheld keypad than a phone. These time outs effect how long it takes a call to be cleared after the last DTMF key is pressed
- **Auto Dial:** If set, the SatRADIO will auto-dial the number in Quick-Dial-0 location when the radio is On, and the Dial input signal is enabled. If clear then the last number dialled on the Iridium handset will be called (re-dial mode) when Dial input signal is enabled, or manual PIN protected DTMF dialling is available when Dial input signal is disabled.
- **Manual Quick Dial:** It is possible to configure up to 10 quick-dial memories with phone numbers for use when manual DTMF dialling from a handset. There are 10 quick-dial memories, and these can be called using the sequence: PIN0->9,*,

- **Gains, Upstream, Downstream & Tones** may need to be optimised for a particular radio. Different radio manufacturers have different line levels on their radio interface connections, and therefore to get the best audio these gains may need to be adjusted.
- **VOX threshold.** When the remote side speaks, a voice activity detector (VOX) is used by the SatRADIO to key the SatRADIO transmitter. Small adjustments to this voice detector are possible using the **SLIC On** (activity level required to key-up) and **SLIC Off** (activity level required to drop under to key-down once keyed up) parameters.

Specification Summary

Electrical	
Input Power	10-32VDC 5A
Power Consumption (Average Power)	
Standby Mode	5W
Talk/Transmit Mode	Receive 7W Transmit 7W
Intelligent Satellite Handset	
Voltage	+12VDC
Audio	Line level
Digital Control	115kbps RS232
RF Interface (L-Band Transceiver)	
Frequency range	1616MHz to 1626.5MHz
Average Power	7W during a transmit slot (max)
Average Power	0.6 W during a frame (typical)
Receiver Sensitivity	-118.5 dBm at 50W (typical)
Receiver Spurious Rejection at offsets > 1 MHz (typical)	60 dB
Duplexing method	TDD (Time Domain Duplex)
Oscillator stability	±1.5ppm
Input/output impedance	50 Ohms – TNC F Connector
Multiplexing method:	TDMA/FDMA

Environmental	
Operational Temperature	-30°C to +60°C
Storage Temperature	-40°C to +80°C
Vibration	MIL-STD-810F 514.5
Temperature	MIL-STD-810F 501.4
Humidity	MIL-STD-810F 507.4
Product Sealing	IEC529 rating IP54
Certification	
RST820 EMC/EMI Compliance	EN61000-6-2, EN61000-6-4, EN61000-3-2, EN61000-3-3, FCC Part 15B Class A, C Tick CISPR22 Class A

Additional Certification for Iridium Transceiver:

The following harmonised standards have been applied to the design of the L-band transceiver:

Standard	Description
EN 60950-1:2001	Information technology equipment – Safety – Part 1: General Requirements
EN 301 489-20V1.2.1 (200211)	Electromagnetic compatibility and Radio Spectrum Matters (ERM);
EN 301 489-01v1.4.1 (2002-08)	Electromagnetic compatibility (EMC) standard for radio equipment and services.
ETSI EN 50360:2001	Product standard to demonstrate the compliance of mobile phones with the basic restrictions related to human exposure to electromagnetic fields (300MHz to 3GHz)
ETSI EN 301 441 V1.1.1 05/2000	Satellite Earth Stations and Systems (SES); Harmonised EN for Mobile Earth Stations MESs)

BEAM Warranty Conditions

BEAM Communications gives this express warranty (along with extended warranty endorsements, where applicable) in lieu of all other warranties, express or implied, including (without limitation), warranties of merchantability and fitness for a particular purpose. This constitutes our sole warranty and obligation with regard to our products as well as the Customer's sole remedy.

BEAM Communications expressly disclaims all liability and responsibility for any special, indirect or consequential damages or any further loss of any kind whatsoever resulting from the use of our product(s). The Customer's sole and exclusive remedy and the limit of BEAM liability for any loss whatsoever, shall not exceed the purchase price paid by the Customer for the product to which a claim is made.

All products manufactured by BEAM Communications are warranted to be free from defects in material and workmanship in accordance with and subject to the following terms and conditions:

1. This warranty is limited to the original Customer only. It cannot be transferred or assigned to third parties unless the intent to transfer to a third party is expressly indicated in a purchase order and/or warranty-processing arrangements have been agreed upon in writing by BEAM.
2. BEAM Communications does not warrant any installation, maintenance or service of the Products not performed by BEAM, nor does it warrant the use of Products with unapproved ancillary products.
3. BEAM Communications will correct any defects in material or workmanship of products manufactured by BEAM which appear within (12) months, from the date of shipment by BEAM Communications to the Customer. BEAM Communications will repair or replace, at our option, any defective product, provided that our analysis and/or inspection discloses that such defects developed under normal and proper use.
4. This warranty does not extend to goods subjected to liquid or particulate ingress, extreme humidity, misuse, neglect, accident or improper installation, or to maintenance or repair of products that have been altered or repaired by anyone except BEAM Communications unless otherwise stated in writing.
5. The warranty is a return-to-base warranty and freight is paid by the sender.
6. A charge of USD150 including return freight will be made for testing returned product which is not defective or is found to be defective as the result of improper use, maintenance or neglect.
7. BEAM Communications will not accept responsibility for any invoiced goods or services that are not covered by a BEAM Communications written purchase order. Under no circumstances does BEAM Communications agree to pay for labour or other related expenses associated with the troubleshooting and/or repair of our product without prior specific written authorization.
8. Information in our descriptive literature is based on product specifications that are current at the time of publication. Product specifications, designs and descriptive literature are subject to change as improvements are introduced. Although we announce changes as they occur, we cannot guarantee notification to every Customer. BEAM Communications warrants delivered product to conform to the most current specifications, designs and descriptive literature.
9. This warranty policy may be expanded or limited, for particular categories of products or Customers, by information sheets published as deemed appropriate by BEAM Communications. The warranty for third party Products is that of the third party and not BEAM warranty.