



RST410

Man Down Pendant Kit



Suitable for Beam Tracking Terminals
& Other Comparable Devices.

Beam Communications Pty Ltd

Man Down Pendant RST410 Installation and User Guide

Product name: RST410 Mandown

Manual revision: 01

Part Number: USRMAN005601

Release date: April 2010

BEAM Communications Pty Ltd
8 Anzed Court, Mulgrave,
Victoria, 3170, AUSTRALIA

Information furnished by BEAM Communications Pty Ltd (BEAM) is believed to be accurate and reliable. However, no responsibility is assumed by BEAM for its use, or for any infringement of patents or other rights of third parties, which may result from its use.

No license is granted by implication or otherwise under any patent or patent rights of BEAM. BEAM reserves the right to change specifications at any time without notice.

Copyright © 2010 BEAM Communications Pty Ltd. All rights reserved

Package Contents

Check that your Man Down Kit - F5 package contains:

2x AA Batteries

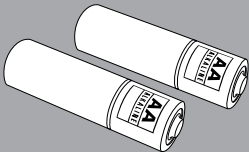

1x Man Down Pendant



1x Pendant Case

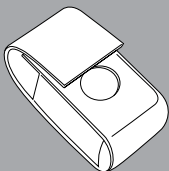

1x Gateway Interface Box

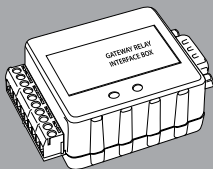

1x Windshield Gateway

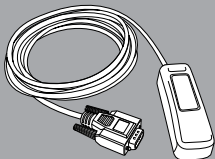

1x Lanyard

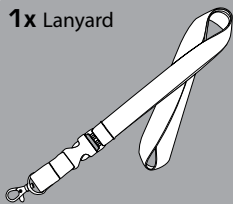

1x Quick Start Guide



Optional Accessories

PotsDOCK 9555

IridiTRAK 430

LeoTRAK 470

LeoTRAK 480

Conventions in this Manual

Warnings, cautions and notes appear throughout this manual and are represented by following conventions.



WARNING / CAUTION:

This symbol and associated text indicate a warning note providing information to prevent damage to equipment or personal injury.



NOTE / IMPORTANT / TIP:

This symbol and associated text indicate a note providing general operating information.



INTERFERENCE:

All wireless phones may get interference, which could affect performance.



RECORD:

Write details of your unit for easy reference when required. Ideal when troubleshooting.

Contents

User information	2
Package Contents	3
Optional accessories	4
Conventions in this manual	
BEAM Communications	7
About this equipment	8
Key features	
Equipment overview	
Installation Guidelines	9
Device connection	
RST430 IridiTRAK wiring diagram	10-11
Connecting to a RST430 IridiTRAK	12
Connecting to a PotsDOCK 9555	13
PotsDOCK wiring diagram	14
Use	15
Emergency alert message generation	
Confirmation of emergency alert	
Turning the pendant on or off	16
Physical Specifications	18
Man Down pendant mechanical drawings	
Windshield gateway mechanical drawings	
Specification and Approvals	19
Environmental specifications	
Technical support/Warranty	
Assuring quality of Iridium service	20
Obstructions	
Cabling	
RF Interference	21
Symptoms of RF interference	
Mitigation of RF interference	
Beam Warranty Conditions	22

BEAM Communications



Beam Communications, a wholly owned subsidiary of World Reach Limited (WRR), listed on the Australian Stock Exchange, is a world leader in design, manufacture and distribution of specialized communications equipment for the Iridium Satellite Network.

Beam's commitment to be at the forefront has continued to increase its share of the global satellite communications market. Its premium distribution network spans the world.

Recognized as a leading provider of satellite communication solutions, **Beam** specializes in Voice, Data, Tracking and customized solutions. Beam develops innovative products and services to meet market demands and niche applications.

Beam's leading edge products are deployed in a wide range of vertical markets including Maritime, Transport, Government, Defence, Mining, Construction, Forestry, Emergency Services, Relief Aid, Telemetry and Rural Telephony.

Supported by a dedicated team of professionals, **Beam** has developed solid relationships with its peers and network of distributors worldwide.

BEAM Communications Pty Ltd
8 Anzed Court, Mulgrave,
Victoria, 3170, AUSTRALIA

Web: www.beamcommunications.com
Info: info@beamcommunications.com
Support: support@beamcommunications.com
Tel: +61 3 8588 4500
Fax: +61 3 9560 9055

About this equipment

Key Features

Man Down Pendant

Single large push button
(16 mm, 5/8 in dia.)

Integrated motion sensor triggers
an alert message after 60 seconds
of no motion.

Vibration motor, two bi-color
LEDs and a buzzer act as
feedback mechanisms.

There are two bi-color LEDs on the
device immediately above and to the
right and left of the push button.



Windshield Gateway

The Windshield Gateway mounts
directly to the inside of the vehicle's
windshield. This allows for better line
of sight coverage increasing the range
to the Man Down Pendant.



Gateway Interface Box

The Gateway Interface Box allows
Man Down Pendant/Gateway bundles
to work with Data Communication
Equipment that require switch logic.

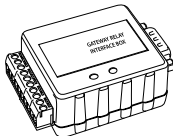

Overview

The Man Down Pendant is a user worn accessory (lanyard or hip holster) that works in conjunction with windshield gateway, gateway interface box, and data communication equipment. The gateway interface box connects to the cellular or satellite modems or other Data Communications Equipment devices and coordinates the panic between the Man Down Pendant and the Data Communications Equipment device.

The Data Communications Equipment device then relays the data to the remote monitoring station using the available transport mechanism. With its integrated motion sensor technology the pendant can recognize if the user has been incapacitated or is unable to press the alarm button.

Feedback mechanisms - LED lights, audible buzzer and vibrate alert - lets the user know the operating status of the pendant.

Installation Guidelines

Device Connections

Data Communication Equipment

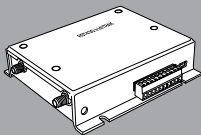

Gateway Interface Box

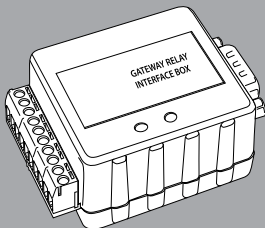

Windshield Gateway

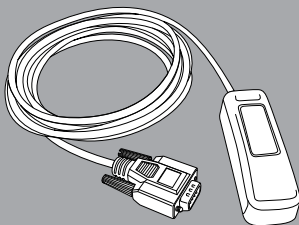

Pendant

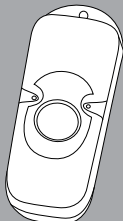

Wired Connection



Wireless Connection

RST430 IridiTRAK Wiring Diagram

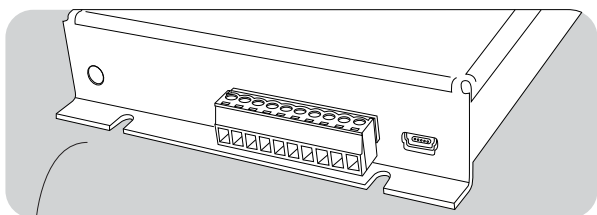

○ Status LED

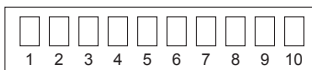

USB (Config Port)

Pin 1 (-) 0V Power Ground

Pin 2 (+) Vin 9 to 32VDC

Pin 3 (IN) On / Off

Pin 4 (IN) Ignition Sense / Accessory

Pin 5 (IN) Alarm Loop A

Pin 6 (OUT) Alarm Loop A

Pin 7 (IN) Alarm Loop B

Pin 8 (OUT) Alarm Loop B

Pin 9 (OUT) LED Out

Pin 10 (IN / OUT) Extra Signal Ground

Pin 1
Pin 2



Power Supply: 20W min.
2A or 3A fuse is recommended.

Pin 3

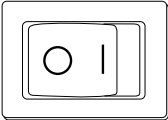

(0 to 32Vdc Tolerant)
ON (1) > +7Vdc
OFF (0) 0V < +1Vdc
When On/Off not required, Wire-link pin 3 to 2 to keep On.

Pin 4

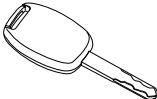

(0 to 32Vdc Tolerant)
IGN ON (1) > +7Vdc
IGN OFF (0) 0V < +1Vdc

* Link (short circuit) unused alarm loops to prevent false alarms.

Pin 5
Pin 6

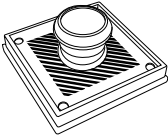

Alarm Loop A * (eg. Button)
Alarm Mode:
"Normally-Closed"
Loop IN to OUT

Pin 7
Pin 8



Alarm Loop B * (eg. Wireless)
Alarm Mode:
"Normally-Closed"
Loop IN to OUT

Pin 9
Pin 10



External LED Driver (optional)
Provides indication of messaging status during alarm triggering.

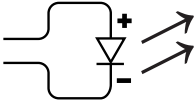

Installation Guidelines

Connecting to a RST430 IridiTRAK

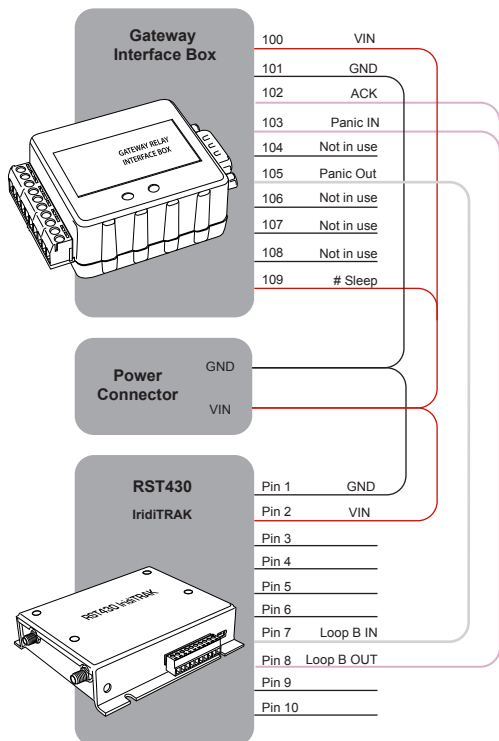

Gateway Interface Box

Signal#	Signal Name	Description
100	VIN	Power supply input 9-26V.
101	GND	Power Ground.
102	ACK	Panic Acknowledgement input.
103	PANIC IN	Common contact for PANIC state controlled relay.
105	PANIC OUT NC	Normally closed contact for PANIC state controlled relay.
109	#Sleep	Sleep Input. Pull to VIN to keep avoid unit going to low power mode.

Connecting to a PotsDOCK 9555

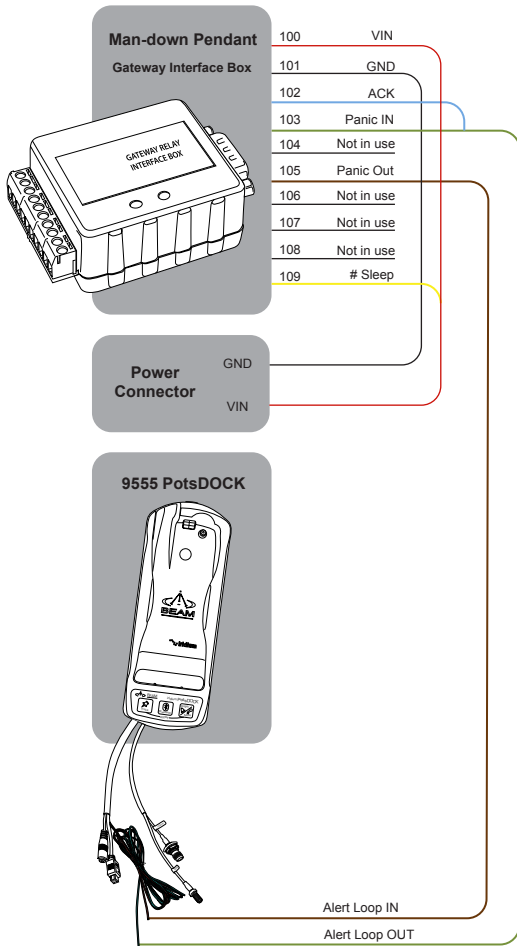

PotsDOCK 9555 Wiring Diagram

Privacy Headset
(optional)

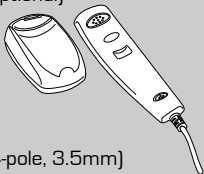

(4-pole, 3.5mm)

Install Power

AC/DC Power Adaptor
(supplied)

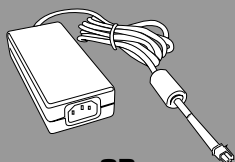

OR

DC Power Lead
(supplied)

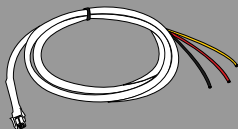

Black

0V Ground to negative battery

RED

+ VIN wire to the vehicle
+ Battery (3A fuse).

YELLOW

Acc (On/Off sense) to vehicle
acc/ Key, or on/ off switch (1A fuse).
If not required, this Yellow wire must
be connected to +VIN (RED wire)

Alert Loop (In/Out)

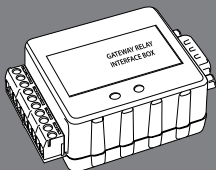

GPS Antenna
(SMA Female)

Iridium Antenna
(TNC Female)

Use

Emergency Alert Message Generation

Pressing and holding the pendant button for more than 3 seconds until both LEDs blink green and orange will trigger an emergency alert notification message. The LEDs will continue to blink until the emergency alert is acknowledged. Upon panic, the gateway interface box will open the 'normally closed connection" for one second allowing data communication equipment device to generate Emergency Alert Message.

Note: The button can be pressed at any time, even when the pendant is powered down. If the button is pressed, the pendant will power up and transmit the alert notification message. When the button is pressed while pendant is powered down, button needs to be pressed for more than 6 seconds, to generate panic.

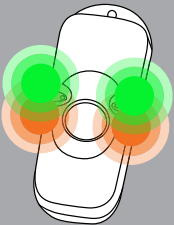

Send EMERGENCY Alert

Press and hold (for > 3 seconds) until both LEDs blink green and orange.

Function	Description
Send EMERGENCY alert	Press and hold for > 3 seconds until both LEDs blink green and orange.

Confirmation of Emergency Alert

If the alert message is successfully delivered to the remote monitoring station a successful acknowledgement will be sent to the pendant indicating help is on the way. If the message fails to reach the monitoring station the pendant will continue to retry indefinitely. If the pendant receives a unsuccessful acknowledgement message, the user is notified via a unsuccessful acknowledgement sound sequence. Upon receiving a successful acknowledgement the pendant will beep twice in an escalating tone and vibrate 4 times. If the message is unsuccessful acknowledged, the pendant will play a high-low sound sequence twice.

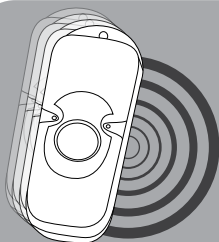

Successful
Acknowledgement

4 Vibrations
2 Escalating Sound
Sequences

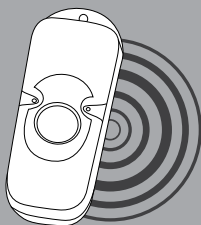

Unsuccessful
Acknowledgement

2 High then Low
Sound Sequences

When an alert notification message has been generated the left and right LED's will both blink alternating between green and orange. This blinking will continue until the alert notification has been acknowledged, either with a successful acknowledgement or a unsuccessful acknowledgement.

Turning the Pendant on and off

There are two ways of turning the pendant on:

1. A quick double click will turn the pendant on.
2. A quick triple click will turn the pendant on in motion sensing mode.

There are two ways of turning the pendant off:

1. A quick double click will turn the pendant off
2. A quick triple click will turn the pendant off when in motion sensing mode

There are two ways to toggle between on and on with motion sensing mode:

1. A quick triple click will take you from on mode to on with motion sensing mode
2. A quick double click will take you from on with motion sensing mode to on mode

For example, when the pendant is off, double click it within one second to turn it on.

See the chart below for further illustration of button sequences.

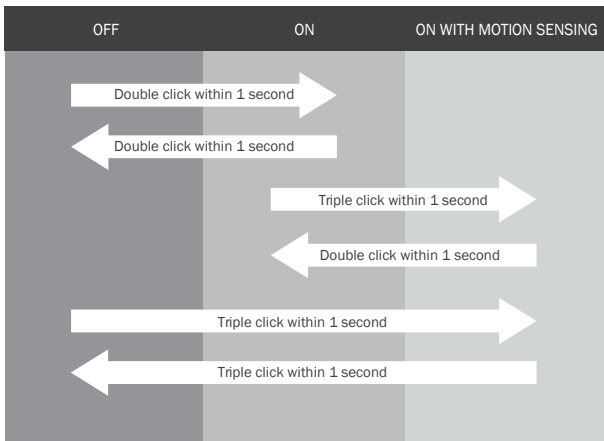

LED's provide an indication to the active mode of the device and there is an audible beep when the device is powered on or off. Two green LED's indicate the pendant is powered on and in range with motion sensing off. An orange (left) and green (right) LED indicate that the pendant is powered on and in range with motion sensing on.

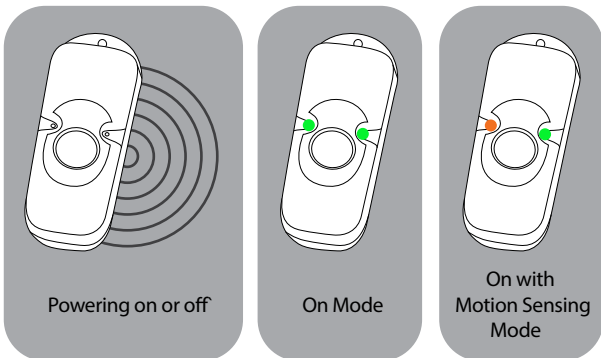

Physical Specification

Man Down Pendant Mechanical Drawings

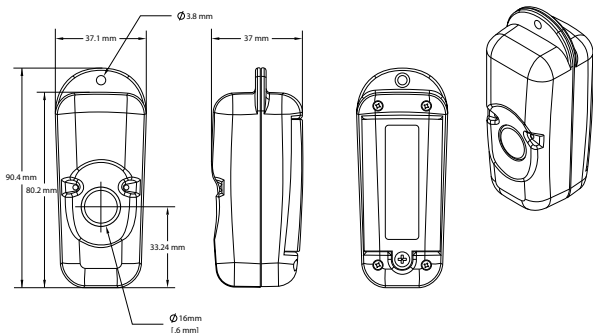

- NOTES
1. WEIGHT: 50 grams
 2. HOUSING MATERIAL: PC/ABS

Windshield Gateway Mechanical Drawings

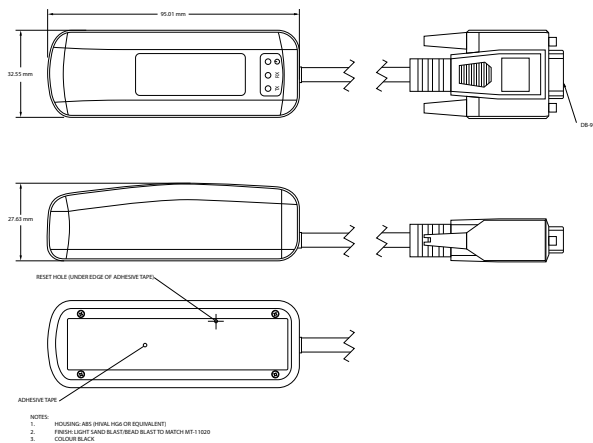

- NOTES:
1. HOUSING: ABS (HIVAL H66 OR EQUIVALENT)
 2. FINISH: LIGHT SAND BLAST/READ BLAST TO MATCH MT-11020
 3. COLOUR: BLACK

Specifications and Approvals

Environmental Specifications

Operating temp = MIL-STD 810F Method 502-II, -30 to +60 Celsius.

Storage Temp = SAE 1455 4.2.3, -40 to +75 Celsius

Humidity = SAE J1455 Humidity test 4.2.3, 85 to 95% RH for
five 48 hour cycles.

Enclosure sealing = IP 54

The pendant has been tested to comply with regulations for license free operation in 2.4GHz band (FCC Title 47, Part 15, Sub part 247)

Technical Support/Warranty:

The Beam website provides product support information including:

News and Releases

Resources

Software tools

Firmware upgrades

For advanced technical support on products contact:

www.beamcommunications.com/support

Assuring Quality of Iridium Service

Iridium is committed to providing subscribers around the world consistent, reliable, quality voice and data access all day every day. The Iridium satellite system is monitored for call performance from numerous locations 24 hours, 7 days a week in order to achieve this.

There are conditions that can compromise the quality of the service you may receive. These include:

- Obstructions
- Cabling
- RF Interference

Obstructions

The antenna must be able to “see” the entire sky from approximately 8 degrees above the horizon. Nearby tall buildings or similar structures, heavily leafed trees and mountains can all degrade performance as they block the signal between the antenna and the satellites. Having a completely open view of the sky plays a very important role in maximising performance, as the Iridium satellites cross the sky from North horizon to South horizon during a connected call.

All surrounding obstructions must be lower than the top of a fist extended at arms length and the bottom of the fist placed on the horizon. Iridium performance is immune from natural environments such as clouds, fog, rain, snow, wind and smoke.

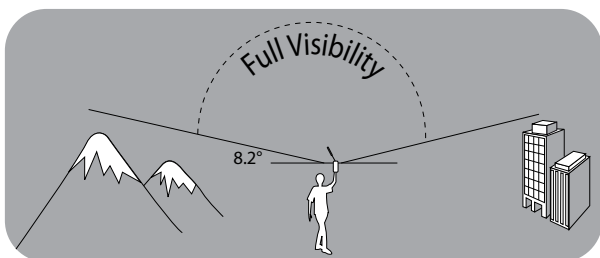

Cabling

Using an externally mounted antenna provides an ideal solution for many applications. If you have or plan to install an external antenna, it is very important that the cables used meet the Iridium guidelines established for proper performance.

For optimal performance, we recommend using the shortest length of cable and the fewest number of connectors possible.

RF Interference

All wireless devices, including satellite telephones, are susceptible to RF (radio frequency) interference from other electronic devices. This problem is more evident when numerous antennas and broadcasting devices are located within close proximity to each other.

Symptoms of RF Interference

Symptoms of RF interference often resemble those that arise when an Iridium phone is being operated with an obstructed view of the sky.

Some of these symptoms include; erratic or no signal strength indication dropped calls or warbled or otherwise distorted voice.

These symptoms may be intermittent or persistent, depending largely on the interference source, its distance, strength and frequency relative to the Iridium unit.

Mitigation of RF Interference

Iridium Service degradation due to RF interference can be significantly improved by:

- a. Increasing the distance and moving the Iridium antenna off axis from the source of the interference, and
- b. Using an external band pass filter and an external antenna.

Beam Warranty Conditions

Beam Communications gives this express warranty (along with extended warranty endorsements, where applicable) in lieu of all other warranties, express or implied, including (without limitation), warranties of merchant-ability and fitness for a particular purpose. This constitutes our sole warranty and obligation with regard to our products as well as the Customer's sole remedy.

Beam Communications expressly disclaims all liability and responsibility for any special, indirect or consequential damages or any further loss of any kind whatsoever resulting from the use of our product(s). The Customer's sole and exclusive remedy and the limit of Beam's liability for any loss whatsoever, shall not exceed the purchase price paid by the Customer for the product to which a claim is made.

All products manufactured by Beam Communications are warranted to be free from defects in material and workmanship in accordance with and subject to the following terms and conditions:

1. This warranty is limited to the original Customer only. It cannot be transferred or assigned to third parties unless the intent to transfer to a third party is expressly indicated in a purchase order and/or warranty-processing arrangements have been agreed upon in writing by Beam.
2. Beam Communications does not warrant any installation, maintenance or service of the Products not performed by Beam, nor does it warrant the use of Products with unapproved ancillary products.
3. Beam Communications will correct any defects in material or workmanship of products manufactured by Beam which appear within twelve (12) months, from the date of shipment by Beam Communications to the Customer. Exception to a 12 months warranty are:
 - Units that do not carry a transceiver (24 months warranty)
 - Accessories (3 months warranty)

Please note that antennas and products not manufactured by Beam also come with a 12 month warranty.

Beam Communications will repair or replace, at our option, any defective product, provided that our analysis and/or inspection disclose that such defects

developed under normal and proper use.

4. This warranty does not extend to goods subjected to liquid or particulate ingress, extreme humidity, misuse, neglect, accident or improper installation, or to maintenance or repair of products that have been altered or repaired by anyone except Beam Communications unless otherwise stated in writing. If a product has been tampered with (e.g.; warranty seal has been removed, wrong cable has been used with an antenna), the warranty will be void.
5. The warranty is a return-to-base warranty and freight is paid by the sender.
6. A charge of USD\$195.00 including return freight will be made for testing returned product which is not defective or is found to be defective as the result of improper use, maintenance or neglect.
7. Beam Communications will not accept responsibility for any invoiced goods or services that are not covered by a Beam Communications written purchase order. Under no circumstance does Beam Communications agree to pay for labor or other related expenses associated with the troubleshooting and/or repair of our product without prior specific written authorization.
8. Information in our descriptive literature is based on product specifications that are current at the time of publication. Product specifications, designs and descriptive literature are subject to change as improvements are introduced. Although we announce changes as they occur, we cannot guarantee notification to every Customer. Beam Communications warrants delivered product to conform to the most current specifications, designs and descriptive literature.
9. This warranty policy may be expanded or limited, for particular categories of products or Customers, by information sheets published as deemed appropriate by Beam Communications. In particular, the warranty for third party Products is that of the third party and not Beams warranty.

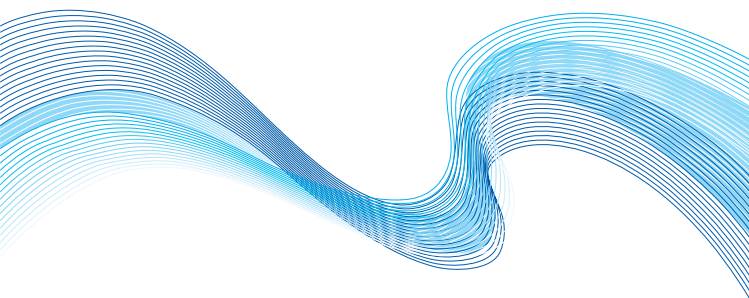

WEB: www.beamcommunications.com
EMAIL: info@beamcommunications.com
PHONE: +61 3 8588 4500
FAX: +61 3 9560 9055



AFRICA | ASIA | AUSTRALIA | EUROPE | MIDDLE EAST | NORTH AMERICA | SOUTH AMERICA